



## Features of FINECAUSE Smart Pad Printer

ATTN : Chris Chuang

SKYPE : fine.cause

TEL : +886-2-8686-9292 Ext.:104 ; FAX : +886-2-8686-3352

Email : Chris@finecuase.com.tw

Web : [www.finecause.com](http://www.finecause.com)

Address : No. 82-3, Dongshun St., Shulin Dist., New Taipei City 238, Taiwan.

2016/05/16

# Feature One

## HMI Touch Panel

# Smart Pad Printer – Output Capacity Data Recorder

- ▶ Display daily output capacity & operating time by bar chart
- ▶ Reveal the cycle time of present printing movement
- ▶ Marking the highest daily result on bar chart in the current month

## FINECAUSE

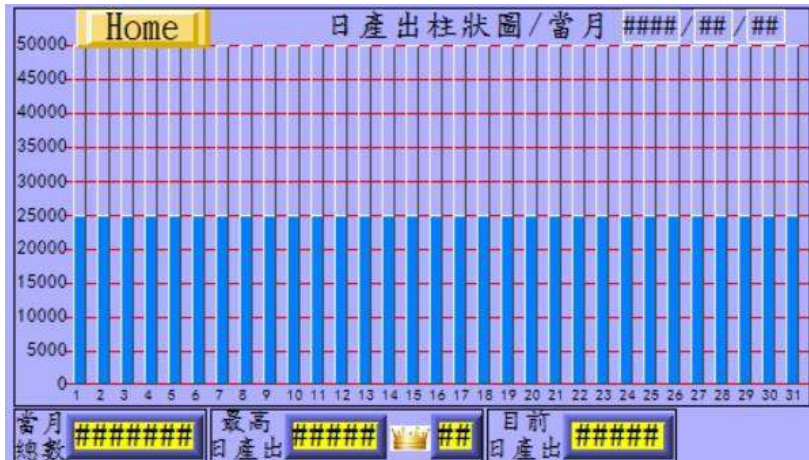

## 4.3' inches 65536 Full Color TFT Touch Panel

- ▶ Human interface, function hint with text display.
- ▶ Language can be switched to **Chinese/English/Indonesian** version.
- ▶ All of FINECAUSE printers are equipped with HMI.

### FINECAUSE



### Other Brands



- ▶ Popping out the error message on screen when printer gone wrong.
- ▶ Display scrolling text, light signal drawing commentary.
- ▶ Finding out the error and troubleshooting instantly.

## FINECAUSE

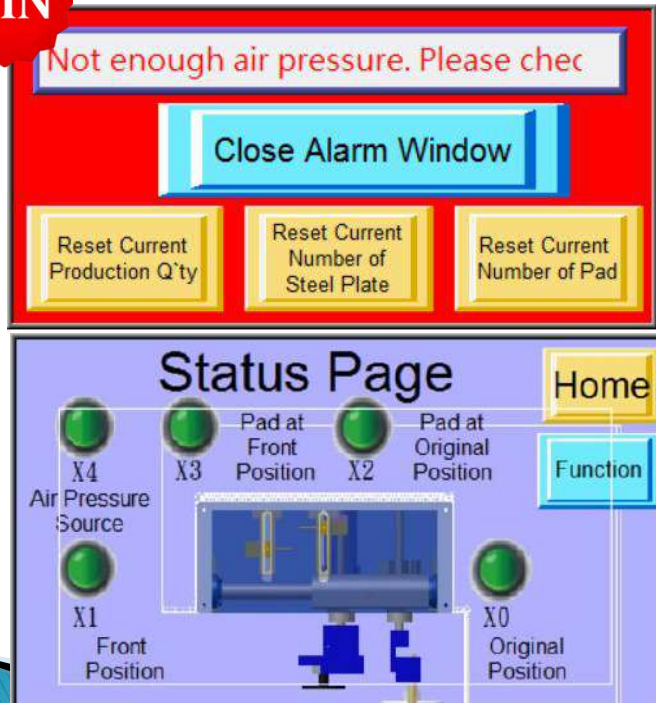

## Other brands

Only can display a code for error, need to read instruction manual for troubleshooting.



- ▶ All parameters of printer can be modified easily.
- ▶ Improving the print quality by setting parameters.
- ▶ Adding functions like **Suction, Fixture, Rolling**.

It can be done easily **by programming the P.L.C.** & full color HMI without setting complex wiring & components.

## FINECAUSE

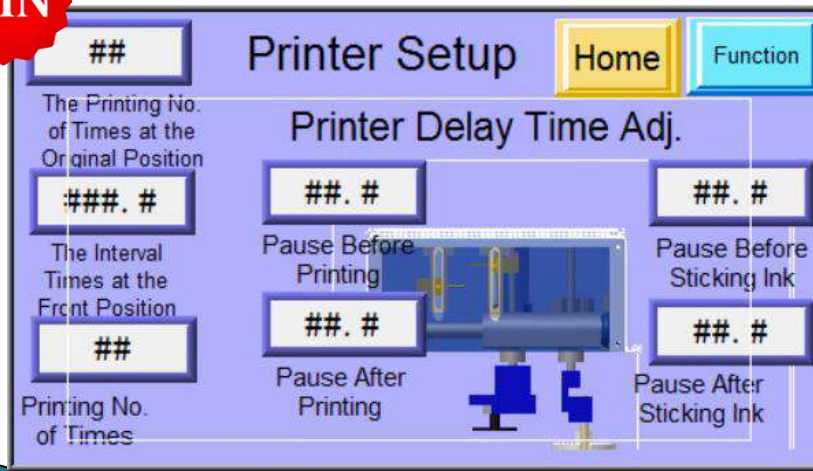

## Other brands

Without this function



- ▶ Not only the **producing quantity** but also the **print time of print plate & rubber pads** can be counted & recorded.
- ▶ Effective way to **save cost** & manage the consumables consumption by setting certain parameter.
- ▶ Display scrolling text if number of time reaches the parameter.
- ▶ This function can be switched on/off by user.

## FINECAUSE

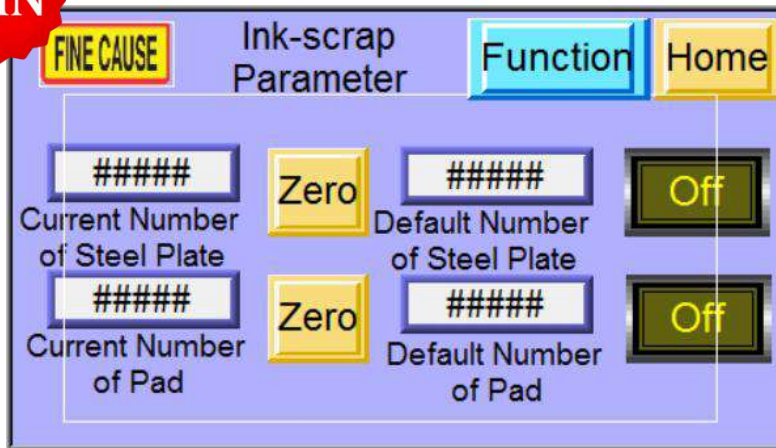

## Other brands Without this function



- ▶ All functions are divided by major sections in order to bring a clear interface to user.
- ▶ Some of functions can be invisible in order to avoid mistouch by user and cause quality gone bad.

## FINECAUSE



## Other brands

Without this function





# Feature Two

## Structure & Appearance

## FINECAUSE

### FC-161ANC (φ60 inkcup)

Dimension : 70 x 40 x 135 cm

Weight : 105 KG



## Other brands

### WE-251 (φ60 inkcup)

Dimension : 75 x 42 x 140 cm

Weight : 111 KG



- ▶ Air intake is installed on left side with no bulge design, it helps to prevent any damage cause when you're moving machines.
- ▶ **Digital air pressure sensor**, alarming when the pressure is lower than 4.5kgs.

## FINECAUSE



## Other brands (Without this function)



- ▶ Whole machine is made of **high precision metal case & powder-paint coating**.
- ▶ Fashion appearance (Taiwan Patent No. M456283), firm and steady.
- ▶ Pneumatic & electronic components are provided by Taiwanese well-known manufacturers.



## FINECAUSE



## Other brands (Aluminum alloy casting)



- ▶ **Adjustable Ink-Scraping Pressure Device** (Taiwan Patent No. M311585), effective to extend the service life of print steel plate and ink cup.
- ▶ Auxiliary horizontal spring and **magnetic ink-scraping cup**, make it more clean and no ink remaining.

## FINECAUSE



## Other brands

Doctor blade of ink cup is directly contact on Print Plate surface.



Our machines can apply for **thick & thin** print steel plate.

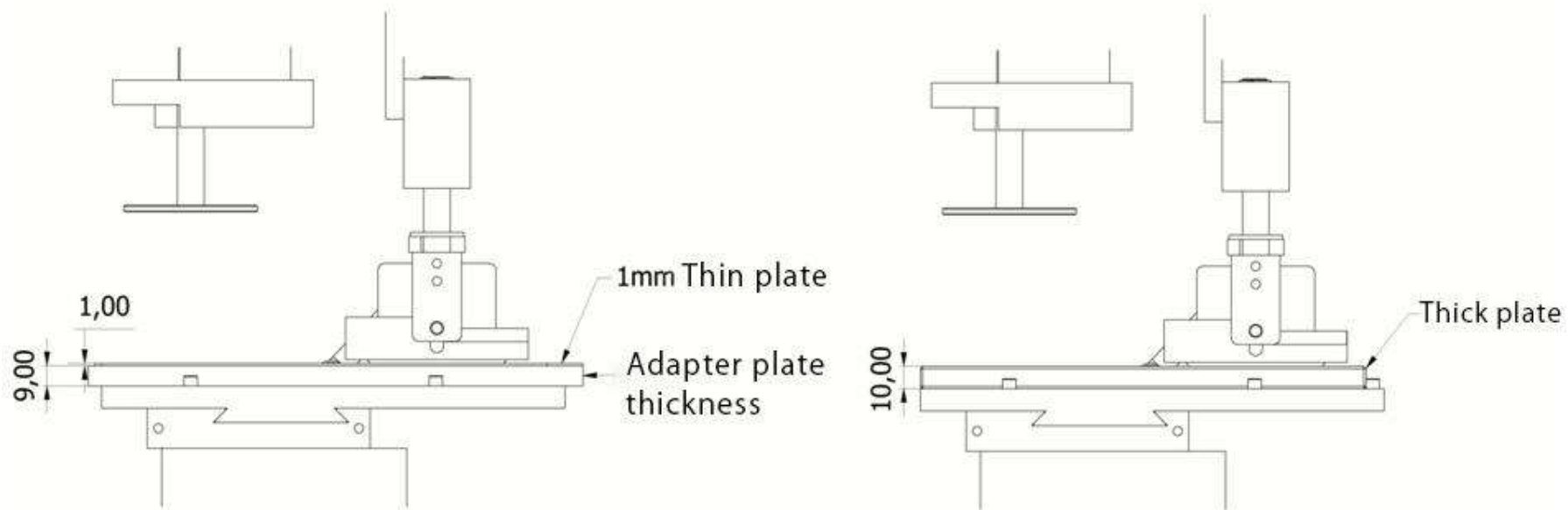

- ▶ The main control circuit is equipped with **PLC**, it's **less space occupying**, **low breakdown rate** and quick service.
- ▶ **PCB has high breakdown rate** and the substrate is easy to corroded, because it made by hundred piece of electronic components. One component breakdown, and it will unable to operate.

**FINECAUSE**  
(PLC Programming)  
Size : 100 x 70mm  
Cost : NTD\$ 5,000



**Other brands**  
(Traditional PCB)  
Size : 250 x 150mm  
Cost : NTD\$ 8,800



# FC-161ANC (φ60 inkcup)



- ▶ **Adjustable Ink-Scraping Pressure Device** (Taiwan Patent No. M456283), effective to extend the service life of print steel plate and ink cup.
- ▶ Auxiliary horizontal spring and **magnetic ink-scraping cup**, make it more clean and no ink remaining.
- ▶ The main control circuit is equipped with **PLC**, it's **less space occupying**, **low breakdown rate** and quick service.
- ▶ 4.3' inches **65536 Full Color TFT Touch Panel**
- ▶ Dimension : 70 x 40 x 135 cm  
Weight : **105 KG**



## ▶ Our service included :

1. Pad Printer, Screen Printer and Custom-built machine manufacturing.
2. Screen print frame, pad print steel plate & rubber pads supplying.
3. Exclusive agency for RUCO inks (GE) & SERITEC Squeegees (IT).
4. Print machine Peripherals & Consumables producing.
5. Printing problem solutions providing.

▶ End Product :



For more printer, please visit : <http://www.finecause.com>